

2
3
4
5
6
7
8

LUMENTON ARCHITECTURAL STEP LIGHTS

ARCHITECTURAL



SIX INCH BRICK LIGHTS

LUMENTON

WWW.STEPLIGHTS.COM

SL300

Compact Open Faceplate Step light (Brick Light)

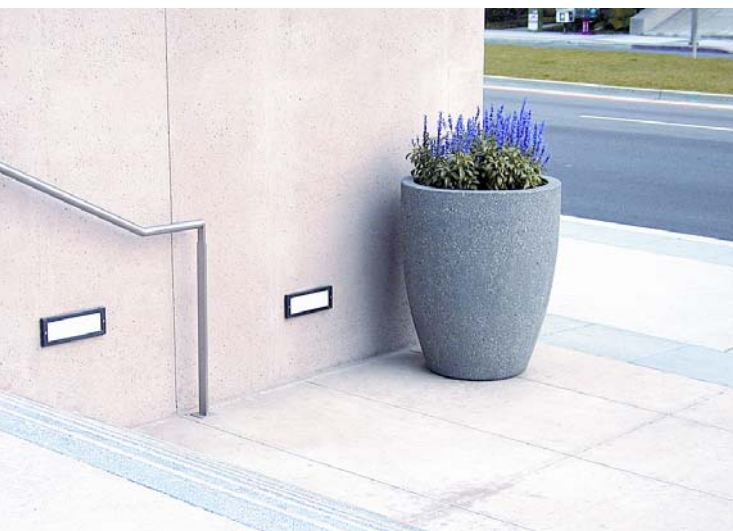
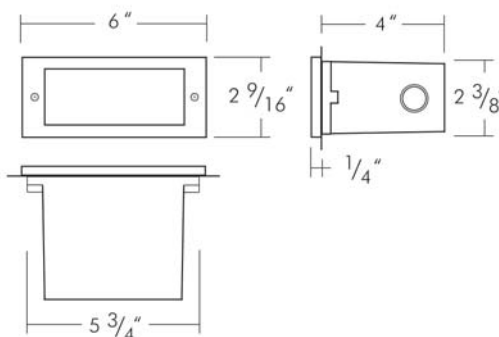

Required Wall Recessed Opening: Width: 5 3/4" x Height: 2 3/8" Depth: 4"

Applications: Recessed Wall Luminaire designed for commercial, architectural, and residential installation. Designed to conform to the architectural requirements for low mounting heights for the illumination of steps, stairways, walkways, aisles, ramps and other indoor and outdoor applications.

Housing: One piece high grade die cast aluminum with a powder coat finish. Includes an integral wiring compartment, reflector and silicone gasket. Two (2) knockouts for 1/2" conduit provided. Can be mounted vertically.

Faceplate: Rectangular open one piece die cast aluminum with powder coat finish and a semi-translucent, sandblasted tempered glass lens. Secured to housing by two (2) tamper resistant, stainless steel screws.

Electrical:

- LED (included): Due to the rapid improvements in LED technology please consult our web site specification sheets and/or factory for the latest available LED's and lamp code information.
- Low Voltage (12V) Lampholder: S8 18W (S818) or S11 25W (S1125) Single contact bayonet base (SC Bay) with ceramic insulator and high temp. leads. Avail with elect. step down transformer, HPF, 120V or 277V (min. start temp. -10°C) or avail. for remote (RMT) 12V, no step down transformer in fixture (order separately).
- Low Voltage (12V) Lampholder: T3 (20W) G4. Halogen porcelain bi-pin lampholder with stainless steel contacts and high temp. leads. Avail. for remote (RMT) 12V only, no step down transformer. Step down transformer by others.
- Line Voltage Lampholder: S11 (25W, 120V) Incandescent Cand. Base with high temp. leads.

Through Wiring: A maximum of four (4) No. 12 AWG conductors (plus ground wire), rated 90°C min.

Finish: Powder coat. Standard color in black, white or natural finish. Custom colors available on special order, supply two (2) samples.

Listing: UL / ETL Listed, suitable for wet location and for all types of constructions including mounting within 1.2 m (4ft) of the ground, use in poured concrete, Type Non-IC (S11 lamp). ADA compliant.

ORDERING

Example : SL300/S818/120/W

SL300 / Lamp / Volt / Finish

Lamp Description	Lumen	Base	Bulb				
Low Voltage							
18W	264	SC Bay	S8	S818	120	B	Black
25W	360	SC Bay	S11	S1125	277	N	Natural
LED							
LED - Consult Factory							
Incandescent							
25W	260	Cand	S11	INC			
Halogen							
20W	350	G4	T3	BPB			

Codes

(A) Architects Choice: Most visually appealing fixture based on lamp type.

(●) Highest Efficacy: Maximum light output per Watt (Lumen/Watt)

RMT - Remote ballast Option (No ballast in fixture)

SL332

Compact Louvered Faceplate Step light (Brick Light)

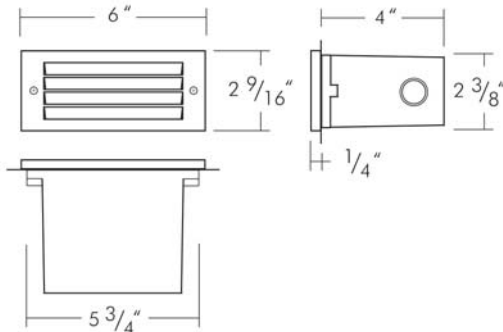

Required Wall Recessed Opening: Width: 5 3/4" x Height: 2 3/8" Depth: 4"

Applications: Recessed Wall Luminaire designed for commercial, architectural, and residential installation. Designed to conform to the architectural requirements for low mounting heights for the illumination of steps, stairways, walkways, aisles, ramps and other indoor and outdoor applications.

Housing: One piece high grade die cast aluminum with a powder coat finish. Includes an integral wiring compartment, reflector and silicone gasket. Two (2) knockouts for 1/2" conduit provided.

Faceplate: Rectangular angled louver one piece die cast aluminum with powder coat finish and a semi-translucent, sandblasted tempered glass lens. Secured to housing by two (2) tamper resistant, stainless steel screws.

Electrical:

- LED (included): Due to the rapid improvements in LED technology please consult our web site specification sheets and/or factory for the latest available LED's and lamp code information.
- Low Voltage (12V) Lampholder: S8 18W (S818) or S11 25W (S1125) Single contact bayonet base (SC Bay) with ceramic insulator and high temp. leads. Avail with elect. step down transformer, HPF, 120V or 277V (min. start temp. -10°C) or avail. for remote (RMT) 12V, no step down transformer in fixture (order separately).
- Low Voltage (12V) Lampholder: T3 (20W) G4. Halogen porcelain bi-pin lampholder with stainless steel contacts and high temp. leads. Avail. for remote (RMT) 12V only, no step down transformer. Step down transformer by others.
- Line Voltage Lampholder: S11 (25W, 120V) Incandescent Cand. Base with high temp. leads.

Through Wiring: A maximum of four (4) No. 12 AWG conductors (plus ground wire), rated 90°C min.

Finish: Powder coat. Standard color in black, white or natural finish. Custom colors available on special order, supply two (2) samples.

Listing: UL / ETL Listed, suitable for wet location and for all types of constructions including mounting within 1.2 m (4ft) of the ground, use in poured concrete, Type Non-IC (S11 lamp). ADA compliant.



2010.4.26

ORDERING				Example : SL332/S1125/277/W			
Lamp Description	Lumen	Base	Bulb	Lamp	Volt	Finish	
Low Voltage							
18W	264	SC Bay	S8	S818	120	B	Black
25W	360	SC Bay	S11	S1125	277	N	Natural
LED							
LED - Consult Factory							
Incandescent							
25W	260	Cand	S11	INC			
Halogen							
20W	350	G4	T3	BPB			

Codes
 (A) Architects Choice: Most visually appealing fixture based on lamp type.
 (●) Highest Efficacy: Maximum light output per Watt (Lumen/Watt)
 RMT - Remote ballast Option (No ballast in fixture)

Remote Transformer

Applications: To remote low voltage fixtures away from Remote Magnetic Transformers. Common uses are for fixtures with low wattage, fixtures designed for remote ballast, multiple fixtures running off one ballast and a centralized electrical input location for all remote ballasts. For use on top of building, walls, in ground, parks and gardens for in indoors/outdoor locations.

Ballast Box Enclosure: Made from Heavy Duty steel housing. Trade size conduit holes/threaded holes for wire/cord exit.

Electrical (Maximum Load):

- **Maximum Load:** 250/300/500/600/1000/1200 Watts
- **Input:** 120V, 60Hz - 277V
- **Output:** Ranges from 11.5V to 23V, 60Hz

Finish:

- **SW** = Stainless Steel Housing (Wet Location)
- **W** = Black Finish Housing (Wet Location)

Option:

- **27** = 277V
- **B** = Boost Tap

Finish: Standard colors in black ("W" option - Heavy Duty Steel Housing).

Listing: UL and CUL Listed, suitable for wet locations (options "SW" and "W").

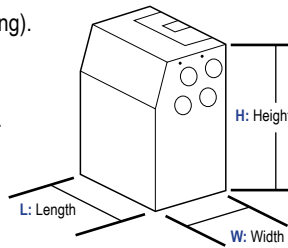

ORDERING

Example: LF CM -

LF / Wattage (CM)			Finish - Option	
(L) Length	(W) Width	(H) Height		
3 3/8"	3"	6 3/8"	250W	250CM
3 3/8"	3"	6 3/8"	300W	300CM
4 3/8"	3 5/8"	7 1/4"	500W	500CM
4 3/4"	3 3/4"	6 3/4"	600W	600CM
5 1/2"	5 1/2"	4 5/8"	1000W	1000CM
5 1/2"	5 1/2"	4 5/8"	1200W	1200CM
Wattage (CM)				
Finish			Stainless Steel Hsg. (Wet Location)	SW
			Black Finish Hsg. (Wet Location)	W
Option			277V Input	- 27
			Boost Tap	- B

ORDERING EXAMPLES

1. LF 250CM-SW = Magnetic Transformer, 250W Max. Load, Stainless Steel Hsg
2. LF 600CM-W-B = Magnetic Transformer, 600W Max. Load, Black Finish Hsg, With Boost Tap

Transformer Selection: The total wattage of all the lamps used on a transformer must not exceed nor go below the rating of the transformer used.

A good rule of thumb to use for the maximum number of watts per transformer, is to allow at least (1) fixture wattage less per each transformer.

For example: If the transformer you plan to use is rated at 300 watts and you have either one (1) or (2) circuits on a transformer with 5 fixtures at 50 watts per fixture, then 5 fixtures X 50 watts = 250 watts.

Voltage Drop: Voltage drop is the lost over the length of a circuit. This means that voltage at the end of the run is lower than voltage at the beginning of the run. Typically, voltage drop at the end of the run should not be less than 1.5 volts. If so, then the efficiency of the equipment may be severely decreased depending on your application.

VOLTAGE DROP FORMULA (12V)*

$$\frac{\text{Total Watts on Cable X Length of Run}}{\text{Cable Size Constant}} = \% \text{ of Rated Candle Power}$$

* Based on a 12V system. Your calculations may vary.

LAMP LIFE EXPECTANCY

Voltage at Lamp	Life Expectancy of Lamp	% of Rated Candle Power
12.6	3/4 Rated Life	180 %
12.0	as Rated	100 %
11.5	2 Times Rated Life	80 %
11.0	3 Times Rated Life	74 %
10.5	5 Rated Life	65 %
10.0	9 Times Rated Life	50 %

USING VOLTAGE DROP TO ADVANTAGE
Voltage Drop is not always bad.
For example, dropping the voltage to 11V gives you 300% longer lamp life with only a 25% lumen/power loss.

See TRANSLIGHT CATALOG for more detailed information.

VOLTAGE DROP: DISTANCE (ft)

	12V Terminal Setting			12V Terminal Setting			24V Terminal Setting			24V Terminal Setting		
	12 AWG	10 AWG	8 AWG	w/Boost Tap*	10 AWG	8 AWG	12 AWG	10 AWG	8 AWG	12 AWG	10 AWG	8 AWG
50	129	204.5	317	216	340	528	519	818	1267	865	1363	2112
100	65	102	158	108	170	264	259	409	633	432	681	1056
150	43	68	105	72	114	176	173	272	422	288	454	704
200	32	51	79	54	85	132	130	204	316	216	340	528
250	26	41	63.4	43.3	68.2	105.6	104	163	253	173	272	422
300	21.6	34	52.8	36	56.8	88	86.5	136	211	144	227	352

▲ Note: Min. Volts on load at 10.5V @ 20°C; Distance in Feet. ■ Distances in Feet at 20°C and 21V on lamps at end of run.

* Boost Tap increases secondary output voltage by 10%. (Be sure to check output voltage at end of run prior to using Boost Tap.)